

Heavy Duty Thermometers Marine Type



STANDARD FEATURES

- Shock and vibration resistant
- Stainless steel construction
- Plastic crystal
- Anti-parallax dial for easy reading
- Accurate to 1% of scale range (when testing without well)
- Interchangeable with 5" scale size *submarine* thermometers having same stem length
- 3/4" -28 UN2A union connection assembly must be used with well (or bushing)
- Does not comply with MIL I-17244E



MADE IN
USA

STANDARD RANGES	
Fahrenheit	
-40 to 120°F	2° divisions
0 to 150°F	2° divisions
0 to 200°F	2° divisions
20 to 240°F	2° divisions
50 to 300°F	2° divisions
50 to 400°F	5° divisions
50 to 500°F	5° divisions
150 to 750°F	10° divisions
Celsius	
-50 to 50°C	1° divisions
-10 to 110°C	1° divisions
0 to 150°C	2° divisions
0 to 200°C	2° divisions
0 to 300°C	5° divisions

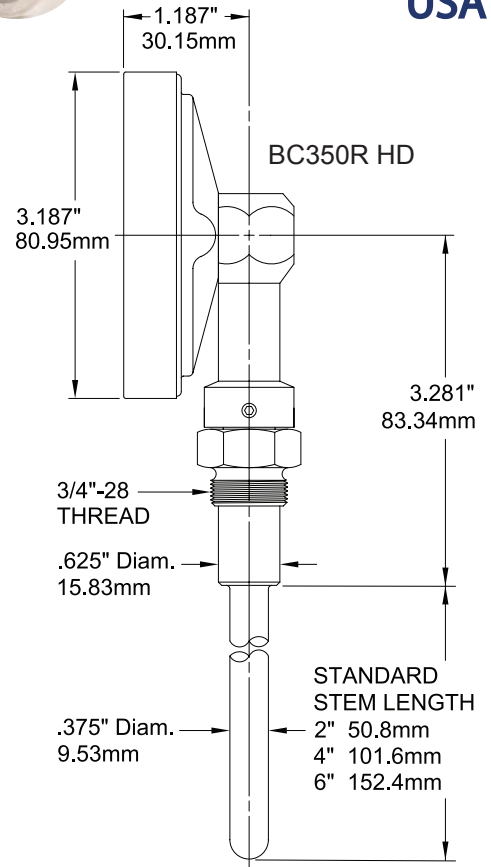
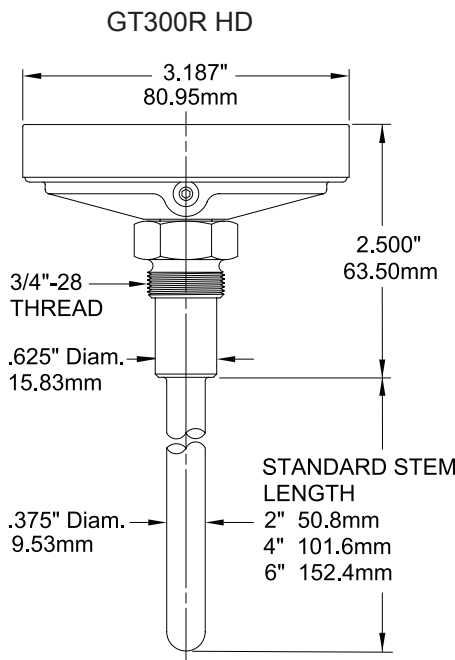

Thermowell Dimensions

3/4" - 28" Female Thread (Internal)

